



GRV43KT

USER MANUAL



For more information
on the Gator range
go to our website

gatordriverassist.com 

Mirror monitor, Butterfly mount camera, 5.5M RCA extension cable,
Mirror monitor harness, Camera harness

Introduction

Thank you for purchasing the Gator GRV43KT 4.3" Display dash mount reverse camera kit. Please ensure that you have read the product manual and instructions in full, prior to installation and use. Failure to do so may result in product failure/damage or incorrect operation and therefore impact the product performance.

Product features & specifications

Monitor

- 4.3" 16:9 High-resolution TFT LCD Screen
- Resolution 480*272 (500 Candela)
- Video Input : Yellow = Reverse Camera Input
- NTSC/PAL
- 12V Compatible
- Power Supply: DC12V +/- 10%
- Secondary Video RCA Input
- Dimensions 88(H) x 116(W) x 34mm(L)

Butterfly Mount Camera

- Aluminum case & waterproof for outdoor use
- 150 Degree wide angle lens
- Parking guide lines
- IP-67 Dust and water protection
- Surface plate mount
- CMOS Sensors
- 0.2 Lux
- NTSC
- 5.5M Video extension cable

Table of contents

| | |
|--|----|
| Introduction..... | 2 |
| Product features & specifications..... | 2 |
| Table of contents..... | 3 |
| Installation diagram..... | 4 |
| Installing the camera..... | 5 |
| Installation of the Monitor..... | 7 |
| Testing the reverse camera function..... | 7 |
| Menu options and settings..... | 8 |
| Troubleshooting guide..... | 9 |
| Safety information & warnings..... | 10 |
| Technical assistance..... | 11 |

Installation diagram

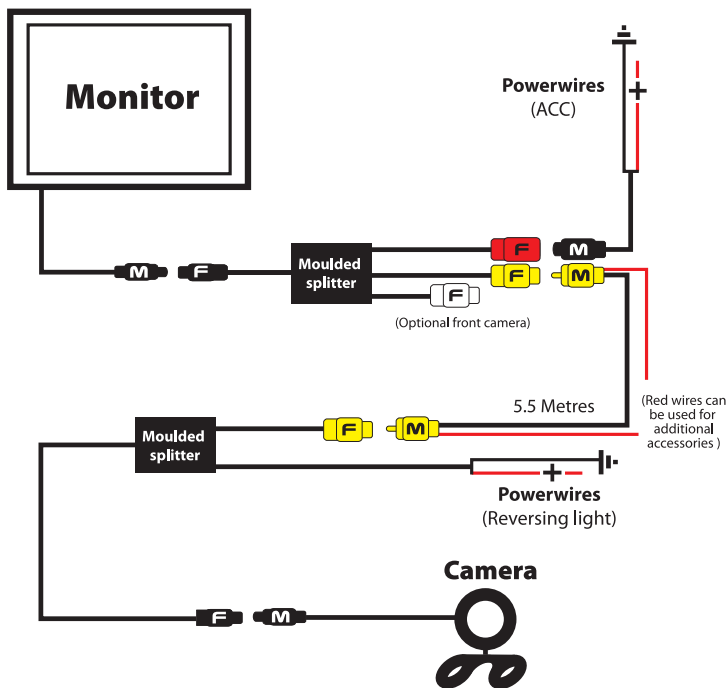

The video signal is transferred from the camera to the GRV43KT monitor via an RCA cable that will need to be run through the boot, through the passenger compartment to the monitors wired loom run under the dash. From there the power and video signals are sent directly to the monitor. At the rear of the car the camera is powered directly from the reversing tail light. Priority is the AV2 input.

Installing the camera

In most instances, the camera is best mounted above the vehicles license plate as shown here.



Fig.1

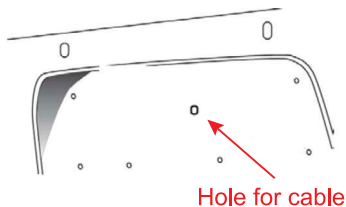

Fig.2

1. Connect the RED wire of the Cameras Power Harness to the wire that supplies power to the reversing light globe (the wire that is energized only when the car is put into reverse). Before making the electrical connection, temporarily disconnect the camera from the power plug whilst making the connection to the reversing light globe. Use a suitable splicing/crimp connector (scotch lock type) or strip connector. This connection can also be soldered, making sure to insulate the joint with electrical insulation when done. The camera has only one wire to connect (positive (+)). There is no need to hook up a ground earth wire as the camera gets its earth through the RCA cable. Hooking up the ground earth may cause a ground loop. In this case horizontal lines will appear in the image.

NOTE: CAN BUS

In the event that the cars reversing lights are driven by CAN BUS the above wiring system may not trigger the system correctly. It may even create a globe fault warning. In this case a CAN BUS

Installing the camera cont...

module (sold separately) may need to be installed. However, just because the vehicle has a CAN BUS system does not necessarily mean that it will require such a module to work. In fact the opposite is true. Most vehicles do not require an additional module. If a CAN BUS module is required we recommend seeking advice from a professional installer.

2. After you have insulated the join you can connect the power harness to the camera.

NOTE:

Some cars that run LED or computer controlled lighting systems may not deliver enough voltage to run the camera. If the voltage at the reversing wire light is less than +12 volts it may be necessary to use a relay to supply power to the transmitter harness from the wiring in the front of the car. In this case the reversing light only needs to trigger the relay. Make sure that you do not drill holes in the panels that have an opposite face that is visible outside the car for example guard panels. In fact, whenever drilling holes in the bodywork of a vehicle, always see what is on the other side.

3. Connect one end of the supplied RCA cable to the RCA socket from the camera, then run the RCA cable to the front under side of the driver side dash board. This is where the monitor's loom will be located. To do this you will need to remove the rear seat to pass the cable into the cabin area and you will need to remove the door scuff plates to run the wire along the side of the vehicle. The RCA cable will be hidden when you replace the scuff plates. When the cable is at the front of the vehicle the RCA cable needs to be run from the scuff plate area to the underside of the dash behind the kick trim (remove and run cable).

Installation of the Monitor

4. The monitor has two power wires to be connected. Connect the red wire (accessories +12V) to a wire that is energized when the vehicles accessories is turned on. Connect the black wire to a ground earth wire or to the body of the car using the steel of the cars body behind the kick trim as an earth. In this case drill a small hole and connect the wire using a suitable ring terminal. Scrape off the cars paint around the hole to ensure good earth.
5. Connect the RCA cable to the RCA socket from the monitors loom.

Testing the reverse camera function

1. Engage the park brake and turn the ignition key to the on position. **DO NOT** start the vehicle.
2. Select reverse gear with the gear shift. The monitor will sense the video signal from the camera automatically and will display the camera's image of the rear of the vehicle.

Menu options and settings

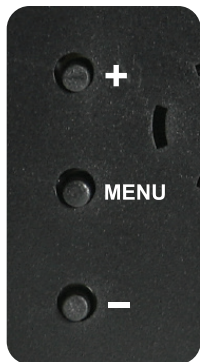

1. Press the **MENU** button for Menu access functions and confirm settings
2. Press the **+** or **-** button repeatedly to increase/decrease value
 - **Brightness:** Adjusts screen brightness
 - **Contrast:** Adjusts screen contrast
 - **Saturation:** Adjusts screen saturation
 - **Language:** Select menu language
 - **Mode:** Changes display mode between 4:3 & 16:9 ratio
 - **Reset:** Resets all menu setting back to factory configuration

Troubleshooting guide

Problem: The Monitor feels warm when it is operating

Solution: • It is normal for the Mirror Monitor to feel warm to the touch during typical use.

Problem: My screen image is blurry, dirty or discoloured

Solution: • Check to see if there are any finger prints or dirt present on the camera lens. If needed, clean with a soft dry cloth before recording.

• Also be sure to have removed the transparent lens/screen cover during installation.

Problem: The Monitor is frozen or not responding

Solution: • Reset the unit by accessing reset function in the menu.

Problem: Unresolved issues

Solution: • Reset the unit by accessing reset function in the menu.

• Contact Gator Technical Department.

Safety information & warnings

- Do not use the Monitor in damp working conditions; the Monitor is not waterproof.

- Do not try opening the shell or trying to repair the Monitor by yourself. If the accessories for the Monitor have any problems, please take it to an authorised repair agent for repair.

- Do not use a chemical substance, cleaning solvent or cleaner to clean the Monitor, please use a moist soft cloth if you would like to clean the Monitor.

- Do not use the Monitor under conditions where dust is present.

- Please pay attention to cleaning the lens surface, use a moist soft cloth to clean the lens before use, to avoid poor image quality

Technical assistance

If you need assistance setting up or using your Gator product now or in the future, call Gator Support. Australia

TEL: 03 – 8587 8898

FAX: 03 – 8587 8866

Mon-Fri 9am – 5pm AEST

Please retain this user guide for future reference.

If you would like to download a digital copy of this manual, or other Gator manuals/software, please visit the gatordriverassist.com website and click on ‘Firmware & Manuals’ or search for the product model number for more information, accessories and products.

This manual is considered correct at time of printing but is subject to change. For latest manuals and updates refer to the website.

Copyright © 2017 by TDJ Australia

All rights reserved. No part of this publication may be reproduced, distributed, or transmitted in any form or by any means, including photocopying, recording, copying or other electronic or mechanical methods, without the prior written permission of the author.

www.gatordriverassist.com

GATER 